

d.scale-HDIIC

Datasheet

Display Controller Board with DP- & HDMI-Input

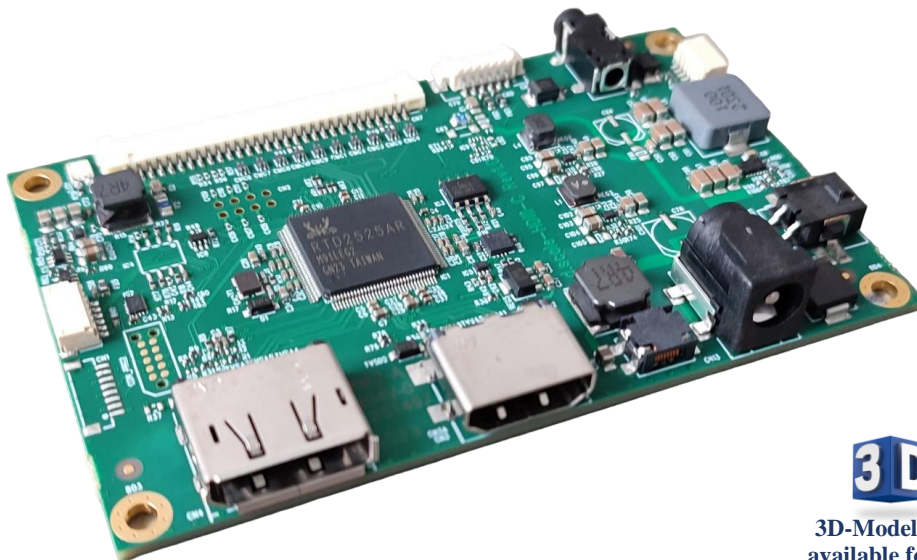

3D-Modell (.stp)
available for your
construction

Rev 1.1

PRELIMINARY

February, 2025

The information given in this document is carefully checked and believed to be reliable. However, Display Solution takes no response for any failure or product damage caused by the application of this information. Please check all connections carefully with the data sheet. Display Solution products are not intended for use in systems in which failures of product could result in personal injury. All mentioned trademarks are registered trademarks of their owner. All specifications are subject to change without notification.

Table of Contents

1	General Description	4
2	Features	4
2.1	Realtek – RTD2525AR Core Features	4
2.2	Video Input Interfaces	4
2.3	LCD-TFT Output Interfaces	5
2.4	Additional Interfaces	5
2.5	Power Supply	5
2.6	LVDS-Data Channels & Mapping	6
2.7	Scaler Control & Status	8
2.8	OSD – On Screen Display	9
2.8.1	System Messages	9
2.8.2	OSD Short-Cuts	10
2.8.3	Onscreen Display Menu (OSD)	10
2.9	DDC/CI (MCCS) Support	15
2.10	Peripherals	16
3	Firmware Configuration & Programming	17
4	Connectors	17
4.1	Video Input	18
4.2	Video Output	19
4.3	Backlight	19
4.4	Board Control	19
4.5	Peripherals	20
4.6	Firmware Programming	20
4.7	Power Supply	21
4.8	Connector Overview	22
5	Specifications	23
5.1	Electrical Characteristics	23
5.2	Temperature & Humidity	23
6	Outline Dimensions	23

Revision History

Date	Rev	Description	Page
January 2024	1.0	First draft	
February 2025	1.1	Release Version	

1 General Description

The d.scale-HDC-IIIC is a LCD-TFT controller board based on Realtek's scaler-SOC RTD2525AR. It provides a DP and a HDMI input and the LVDs output supports any 6-/8-bit LCD-TFT display up to 1920x1080 (FHD) / 1920x1200 (WUXGA). Depending on the board version it is able to work with a single 12V or 24V power supply. The design of the d.scale-HDIIC allows the seamless use of our firmware configuration and programming toolbox.

2 Features

2.1 Realtek - RTD2525AR Core Features

The d.scale-HDIIC is based on Realtek's multi-function display controller RTD2525A which provides the following core features

- Vivicolor™
 - Independent color management (ICM)
 - Dynamic contrast control (DCC)
 - Precise color mapping (PCM)
- Advanced Scaling
 - Advanced zoom algorithm provides high image quality
 - Sharpness/Smooth filter enhancement
 - Support non-linear scaling from 4:3 to 16:9 or 16:9 to 4:3
- Color Processor
 - True 10 bits color processing engine
 - sRGB compliance
 - Dynamic overshoot-smear cancelling engine
 - Brightness and contrast control
 - Peaking/Coring function for video sharpness
- DDC/CI, MCCS (Monitor Control Command Set) support
 - Complete OSD-control via DDC/CI
 - Supports several manufacturer (Display Solution GmbH) specific commands
- Embedded OSD
- Audio support, 2ch Audio DAC

2.2 Video Input Interfaces

- DisplayPort 1.2 via USB Type-C with Alternate Mode support
 - Support 2/4 Lanes up to 1.62Gbps/2.7Gbps/5.4GHz each
 - 6-bit, 8-bit, 10-bit and 12-bit color depth transport
 - Optional HDCP 1.4/HDCP2.2
- HDMI
 - Operating speed up to 225MHz (up to 60 Hz)
 - HDMI 1.4 support
 - 6-bit, 8-bit, 10-bit and 12-bit color depth transport is supported
 - Optional HDCP1.4 support

2.3 LCD-TFT Output Interfaces

The d.scale-HDIIC supports LVDS LCD-TFT displays from VGA up to WUXGA and controls the backlight unit.

- LCD-TFT connection
 - Single/double pixel LVDS output
 - Open-LDI and PSWG (VESA) data-mapping
 - Supports LCD-TFTs up to 1920x1200 and pixel clocks up to 93MHz for single LVDS and 186 MHz for dual LVDS
 - Support for 8 or 6-bit LVDS (with high-quality dithering)
 - Spread-Spectrum DPLL to reduce EMI
 - Supports +3.3V/+5V LCD-TFT logic supply
[LCD-TFT logic supply voltage is controlled by firmware](#)
 - Logic supply is controlled by firmware (no manual jumper-settings required)
- Backlight supply/control
 - Provides backlight-enable and PWM-signal for brightness-control
 - Firmware controlled 3.3V/5V voltage level for ENBKL and PWM signal
 - Optional support for LED backlight converters with I²C-Interface
 - +5V/+12V/(optional up to Vin) supply

Note:

**The display settings (incl. backlight) can be adjusted using the
“Firmware Configuration & Programming Toolbox”**

For further details see chapter-3

2.4 Additional Interfaces

For control and extended functionality the d.scale-HDIIC supports the following options and interfaces.

- OSD-control, interface for an external keypad and dual status LED
- A dual on-board status LED
- 3.5mm audio jack for direct connection of a stereo-headphone (version-dependent)
- Support of I2C peripherals via the MCCS DDC/CI Interface. This interface specified by VESA uses the DDC-channel of HDMI or the AUX-channel of DP, so no additional USB or RS232 etc. connection is required.
 - Version-dependent on-board
 - 3-axis Gyro-sensor for Pivot-functionality
 - temperature sensor
 - I²C-interface for external connection, currently supported:
 - 3-axis Gyro-sensor for Pivot-functionality
 - temperature sensor
 - ambient-light sensor

2.5 Power Supply

The d.scale-HDIIC is available as +12V version or as a +24V version.

- In case of +12V single supply, the backlight-supply voltage is the same as the input-supply voltage.
- The +24V version can provide a +12V backlight supply, but the total power consumption of the display (logic & backlight) must not exceed 30W.

2.6 LVDS-Data Channels & Mapping

The d.scale-HDIIC provides one or two LVDS data channels and supports 6-bit and 8-bit color-depth.

Single channel

Usually LCD-TFT displays with resolutions from VGA (640x480) up to XGA (1024x768) / WXGA (1366x768) are equipped with a single channel LVDS interface whereas with each clock-cycle the data for one pixel is transmitted

➔ These displays have to be connected to the **TXA...- Channel**

NOTE:

If a LCD-TFT display with single-channel LVDS is connected it is essential to ensure that the TXBCLK+/- differential pair is terminated with a 100 Ohm resistor.

➔ If only single channel LVDS is used in the design, please place the termination resistor close to CN7

On the d.scale-HDIIC board the termination resistor is R51

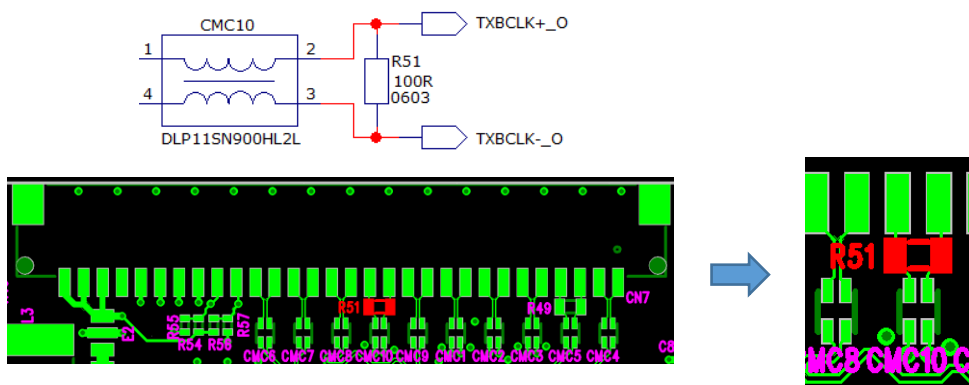

Dual channel

LCD-TFT displays with resolutions from SXGA (1280x1024) up to FHD (1280x1080) / WUXGA (1920x1200) are equipped with a dual channel LVDS interface, whereas with each clock-cycle the data for two pixels is transmitted

➔ These displays have to be connected to the **TXA...- Channel** & **TXB...- Channel**

NOTE

TXA...- Channel

Channel provides the data for the 1. / 3. / 5. / ... pixel

TXB...- Channel

Channel provides the data for the 2. / 4. / 6. / ... pixel

Mapping

Historically, 2 LVDS data mappings have been established, known by different names

Data-Mapping-1 known as:

- Conventional data-mapping
- Open-LDI data-mapping
- JEIDA data-mapping

Characteristics

The LVDS data-pairs TXA3+/- & TXB3+/- transmits the LS-Bits of each color namely Red-0/Red-1, Green-0/Green-1, Blue-0/Blue-1

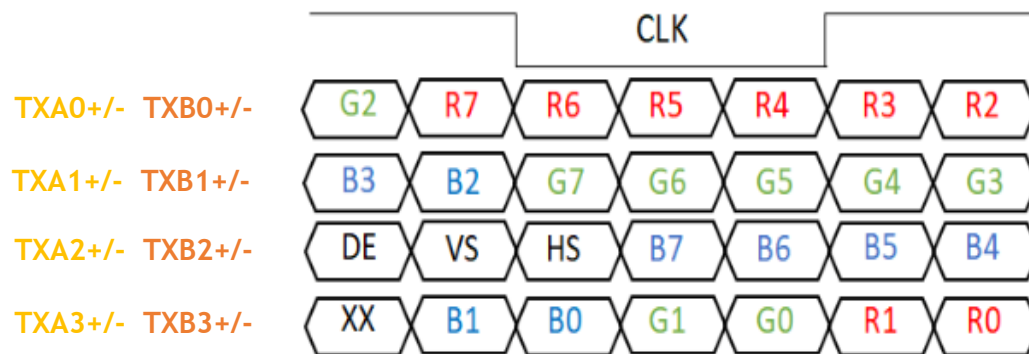

Color-Depth

- Displays with 18-bit color-depth (262K colors) requires TX..0+/- to TX..2+/-
- Displays with 24-bit color-depth (16Mio colors) requires TX..0+/- to TX..3+/-

Data-Mapping-2 known as:

- Non-Conventional data-mapping
- VESA data-mapping

Characteristics

The LVDS data-pairs TXA3+/- & TXB3+/- transmits the MS-Bits of each color namely Red-6/Red-7, Green-6/Green-7, Blue-6/Blue-7

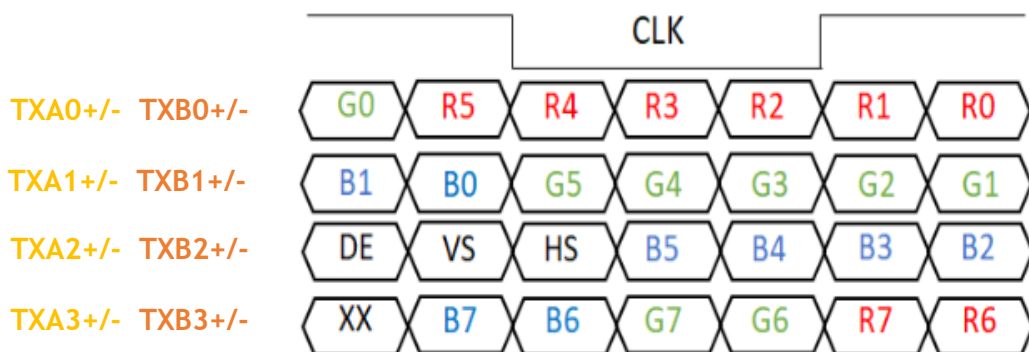

Color-Depth

This data-mappings supports 24-bit color depth (16Mio colors), ONLY.

2.7 Scaler Control & Status

Keypad

The d.scale-HDIIC supports an external keypad to control the OSD-menu. It supports the following buttons:

- Button S1 for power on/off the scaler,
- Button S2 to enter the menu respectively confirm selection
- Button S3 to exit the menu respectively to go one step back
- Button S4 to move left/down respectively decrease the selected value depending on the selected menu status
- Button S5 to move right/up respectively increase the selected value depending on the selected menu status

Depending on the key pressed, the voltage value returned via **KEY** is evaluated. Below the required resistor values are shown. The reference voltage **KEY_REF** is +3.3V and can be drawn from the **KEY_REF** pin.

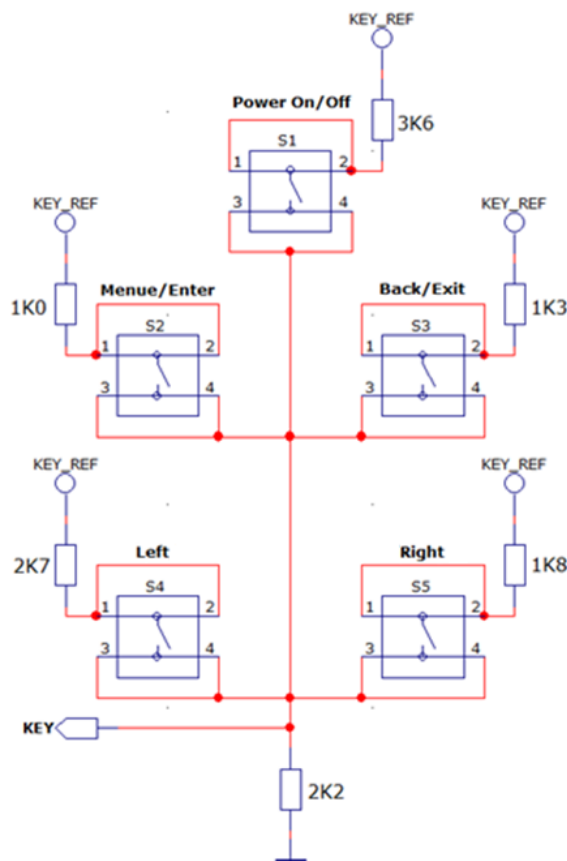

The table below shows keypad functions if OSD is active

Key 5-Button	Function
POWER	Switch On/Off Display
Back/Exit	One Step back / Exit the menue
Menue/Enter	Open OSD-Menue / confirm selection
Right/Up	Move right or up in the OSD
Left/Down	Move left or down in the OSD

Status LEDs

In order to show different system states two GPIOs (push-pull, max.10mA) are available. These GPIOs are provided on CN2 on pins LED1 and LED2. The table below shows the states.

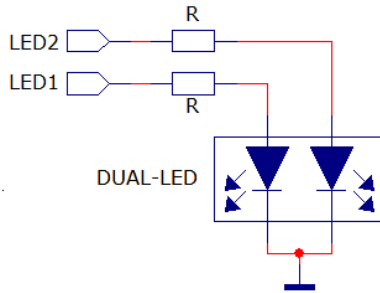

The table below shows the states.

Description	LED1	LED2
Power-off / Standby	Off	Off
Power-on / System start-up, splash-screen is displayed	Off	On
Power-on / No valid video input detected	On	Off
Power-on / Valid video input detected	On	On

2.8 OSD - On Screen Display

2.8.1 System Messages

If no cable is connected to the board the following message is displayed
If no signal is provided: "No Video Signal Detected"

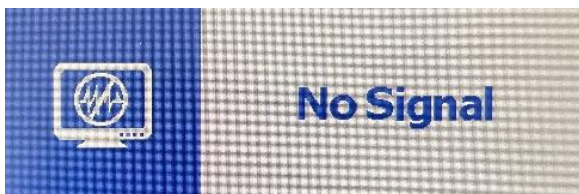

If no valid video signal can be detected the board is powered down and the following message will be displayed

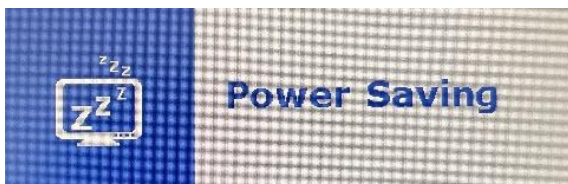

2.8.2 OSD Short-Cuts

Some of the OSD keypad buttons have an additional functionality as long as the OSD dialogue is not entered.

RIGHT / TOP Button

After pressing this button the user will enter the input selector menu. Using this option one of the connected video sources can be selected



LEFT-/ DOWN Button (Blue)

Pressing this button shows the current input



2.8.3 Onscreen Display Menu (OSD)

- To start OSD press the **MENU/ENTER** key.
- Select main/sub menu sections using the **RIGHT** or **LEFT** key.
- Confirm selection by pressing **MENU/ENTER** button again.
- Change values with **RIGHT** or **LEFT** key
- Either confirm with **MENU/ENTER** key or press **EXIT/RETURN** key to dismiss
- Leave OSD using **EXIT/RETURN**

Main Menu Sections

PICTURE

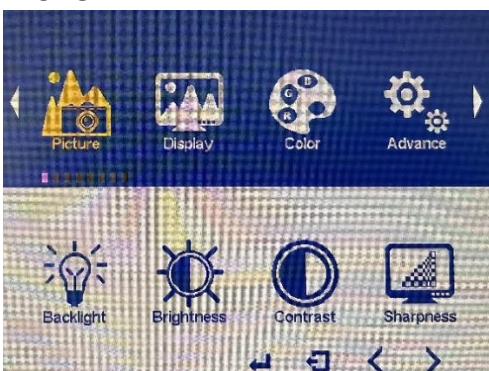

Sub Menu Sections

- **Backlight**
Controls the screen brightness by adjusting the brightness of the backlight (PWM)

- **Brightness**
Controls the screen brightness by adjusting the pixel colour value
- **Contrast**
Controls the contrast of the picture displayed on the screen. Contrast is related to the Y-Domain and affects red, green and blue value.
- **Sharpness**
Controls the sharpness of the picture displayed on the screen

DISPLAY

Only available with analog input

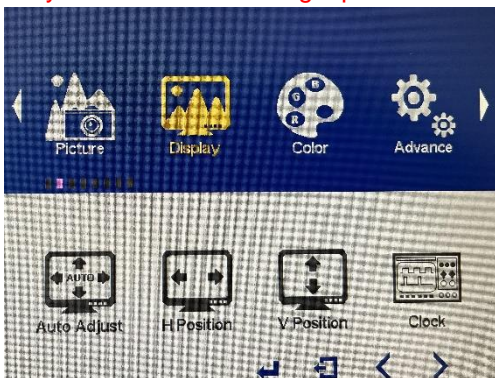

Sub Menu Sections

- **Auto Adjust**
Performs an auto adjust if an analog signal is selected as input
- **H Position**
Using this option the image position can be adjusted
- **V Position**
Using this option the image position can be adjusted
- **Clock**
Adjust the sampling phase of the analog input

COLOR

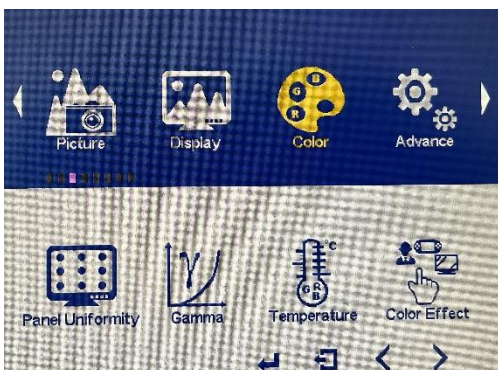

Sub Menu Sections

Panel Uniformity

Can be switched on/off

Gamma

Pre-set Gamma Correction

- 1.8
- 2.0
- 2.2
- 2.4
- Off (default)

Color Temp

- Off (default)
- sRGB (for colour matching with sRGB compatible peripherals)
- 5800K (pre-defined colour temperature scheme)
- 6500K (pre-defined colour temperature scheme)
- 7500K (pre-defined colour temperature scheme)
- 9300K (pre-defined colour temperature scheme)
- **User** User defined adjustment
Sub-Menu > USER Individual adjustment of R, G and B

Color Effect

- Standard (pre-defined colour effect scheme)
- Game (pre-defined colour effect scheme)
- **Movie** (pre-defined colour effect scheme)
- **Photo** (pre-defined colour effect scheme)
- **Vivid** (pre-defined colour effect scheme)
- **User** User defined adjustment
Sub-Menu >USER Individual adjustment of Hue and Saturation separately for R,Y,G, B,M
- **Color Demo** Shows area with special settings
- **Color Format**
 - RGB (default)
 - YUV
- **PCM** Performance Counter Monitor – can be switched on/off
- **Hue** Set this in user mode Colour Effect
- **Saturation** Set this in user mode Colour Effect

ADVANCE

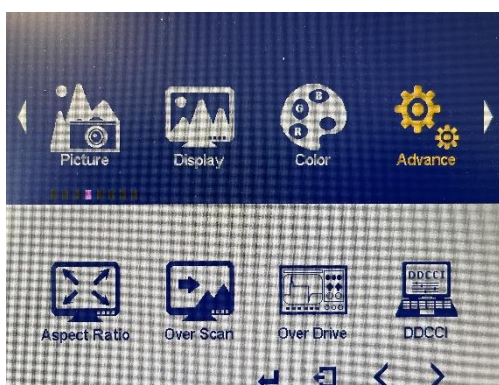

Sub Menu Sections

- **Aspect Ratio**
 - 1:1
 - Full
 - 16:9
 - 4:3
 - 5:4
- **Overscan**
 - On stretches image just beyond the border of display
 - Off
- **Overdrive** Off (always)
- **Energy Star** TBD
- **DDCCI**
 - On Enable external DDCCI access
 - Off Disable external DDCCI access
- **Ultra Vivid**
 - Off
 - Low
 - Medium
 - High
- **DP Option**
 - Version 1.1
 - Version 1.2
 - Version 1.3

INPUT

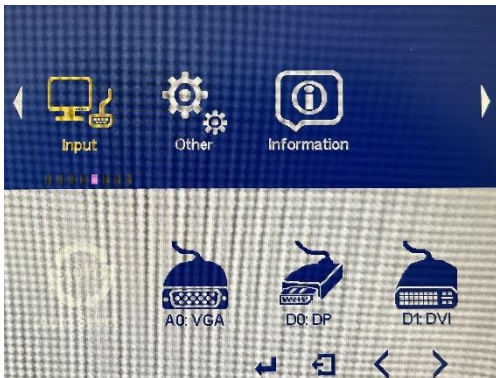

Sub Menu Sections

Using this option one of the connected video sources can be selected

- **Auto Select** This option will select the next active video source automatically
- **VGA** This connected VGA analog signal will be selected as scaler input
- **HDMI** The connected HDMI signal will be selected as scaler input
- **DP** The connected Display Port signal will be selected as scaler input

SOUND (currently not supported)

OTHER

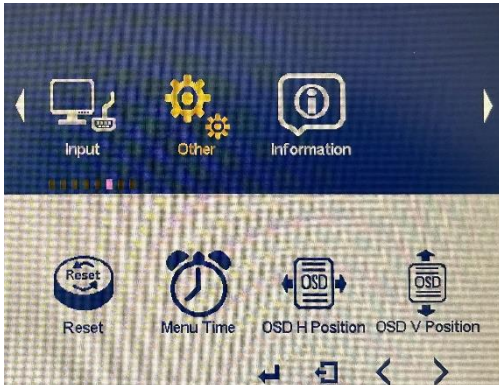

Sub Menu Sections

- **Reset** Select this option to restore the default factory settings
- **Menu Time** OSD menu lasting on screen time Defaults to 10s
- **OSD H Position** Horizontal start of OSD Menu on screen
- **OSD V Position** Vertical start of OSD Menu on screen
- **Language** **OSD** Menu language (for now “English” only)
- **Transparency** Use option to adjust transparency of the active OSD
- **Rotate**
 - 0°
 - 90°
 - 270°
 - 360°

INFO

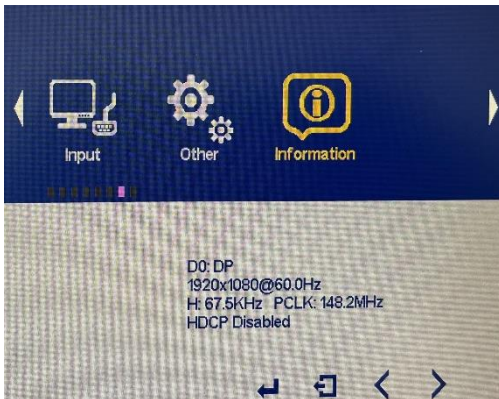

Shows

- Current Mode
- Horizontal and Vertical Frequencies
- Pixel Clock

2.9 DDC/CI (MCCS) Support

OSD defaults

```

code StructOsdUserDataTypes g_stOSDDefaultData =
{
    0xFF,          // ucBackLight;
    100,          // ucOsdHPos;
    100,          // ucOsdVPos;
    10,           // ucOsdTimeout;
    0,            // ucAspectOriginRatio
//-----
    _ENGLISH,     // b4Language;
    _COLOREFFECT_STANDARD, // b4ColorEffect;
//-----
    _CT_OFF,      // b4ColorTempType;
    _COLOR_SPACE_RGB, // b2VGARGBYUV;
    _COLOR_SPACE_RGB, // b2DVIRGBYUV;
//-----
    2,            // b3Sharpness;
    2,            // b3Transparency;
    _OFF,         // b1OsdRotate;
    _ON,          // b1OverScan;
//-----
    _GAMMA_OFF,   // b3Gamma;
    _ASPECT_RATIO_FULL, // b3AspectRatio;
    _ON,          // b1DDCCIStatus;
    _OFF,         // b1OsdESStatus;
//-----
    _OD_GAIN_CENTER, // ucODGain;
    _DEFAULT_HUE,    // cHue;
    _DEFAULT_SATURATION, // ucSaturation;
    _HL_WIN_OFF,    // ucHLWinType;
    0x00,           // uc3DEffect;
    0x00,           // uc3DConvergence;
//-----
    _PCM_OSD_NATIVE, // b2PCMStatus : 2;
    _3D_OFF,         // b23DStatus : 2;
    _3D_MODE_FORMAT_AUTO, // b23DFormatStatus : 2;
    _3D_DISPLAY_RL, // b13DLRStatus : 1;
    _OFF,           // b13D3DTo2DStatus : 1;
//-----
    _ULTRA_VIVID_OFF, // b2UltraVividStatus : 2;
    _OFF,             // b1Osd3DOSD : 1;
    _OFF,            // b1VolumeMute : 1;
    _OFF,           // b1AudioStandAloneStatus : 1;
    0,              // b1AudioSourceStatus : 1;
    _OFF,          // b1ODStatus : 1;
//-----
    50,             // ucVolume;
//-----
    0x00,          // b33DConvergenceMode : 3;
    _AUTO_COLOR_TYPE_EXTERNAL, // b1FactoryAutoColorType : 1;
    0,            // b1SwitchDH : 1;
};
  
```

2.10 Peripherals

I²C-Interface

Via CN6 the d.scale-HDIIC provides an I²C-Interface for connection of useful peripheral devices. The devices can be controlled via the DDC/CI (MCCS) which is a standardized channel by VESA. As physical interface the DDC (HDMI) or the AUX-channel (DisplayPort) is used, which means, that no additional connection like USB or UART is required. The user can select and configure the devices in the firmware configuration tool.

Currently the following devices are supported:

- STMicro / LIS3DH
3-axis Gyro-sensor for Pivot-functionality
- Texas Instruments / TMP102
Temperature sensor
- Texas Instruments / OPT3001
ambient-light sensor

Note:

For further information and code samples ask for the application note:
“AN-MCCS_Manufacturer_Functions_Access_R100”

Analog Audio output (ONLY optional)

Via CN10 an analogue stereo output signal is provided.

3 Firmware Configuration & Programming

It is necessary to adapt the display timing and power on sequencing parameters to the board firmware. Firmware Configuration & Programming for the d.scale-HDIII Family will be done by Display Solution according to the customers display types and needs. Display Solution has developed several programming tools to simplify this process.

4 Connectors

4.1 Video Input

CN3 HDMI

Pin CN23	Signal	Description
1	TMDS2+	Differential TMDS Data 2+
2	TMDS2_SHLD	TMDS Data2 Shield
3	TMDS2-	Differential TMDS Data 2-
4	TMDS1+	Differential TMDS Data 1+
5	TMDS1_SHLD	TMDS Data1 Shield
6	TMDS1-	Differential TMDS Data 1-
7	TMDS0+	Differential TMDS Data 0+
8	TMDS0_SHLD	TMDS Data0 Shield
9	TMDS0-	Differential TMDS Data 0-
10	TMDSCLK-	Differential TMDS Clock-
11	TMDSCLK_SHLD	TMDS Clock Shield
12	TMDSCLK+	Differential TMDS Clock+
13	RSV	Reserved
14	RSV	Reserved
15	SCL	DDC EDID data clock
16	SDA	DDC EDID data
17	DDC/CEC GND	Ground
18	+5V	+5V / 50mA (sink, for HPD & DDC/EDID)
19	HPD	HotPlug Detect

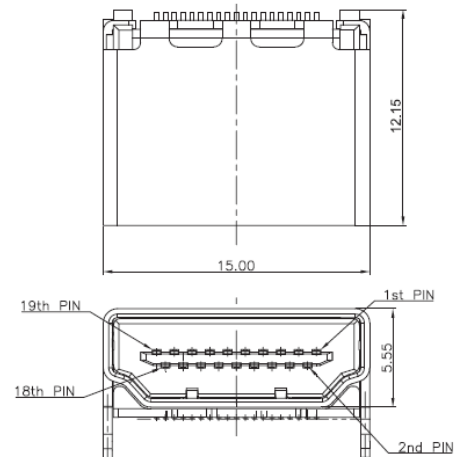

CN4 DisplayPort

Pin CN12	Signal	Description
1	ML_Lane 0 (p)	Lane 0 (positive)
2	GND	Ground
3	ML_Lane 0 (n)	Lane 0 (negative)
4	ML_Lane 1 (p)	Lane 1 (positive)
5	GND	Ground
6	ML_Lane 1 (n)	Lane 1 (negative)
7	ML_Lane 2 (p)	Lane 2 (positive)
8	GND	Ground
9	ML_Lane 2 (n)	Lane 2 (negative)
10	ML_Lane 3 (p)	Lane 3 (positive)
11	GND	Ground
12	ML_Lane 3 (n)	Lane 3 (negative)
13	Config1	Connected to GND
14	Config2	Connected to GND
15	AUX CH (p)	Auxiliary Channel (positive)
16	GND	Ground
17	AUX CH (n)	Auxiliary Channel (negative)
18	Hot Plug	Hot Plug Detect
19	Return	Return for Power
20	DP_PWR	Power for Connector (3.3V/500mA)

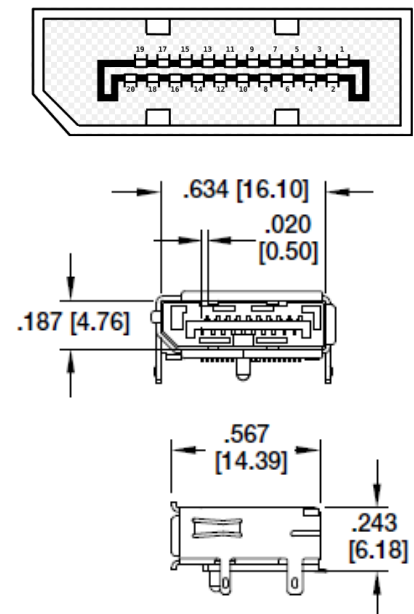

4.2 Video Output

CN7 LVDS Output

Pin	Signal	Description
1	TXA3+	LVDS data 1st pixel
2	TXA3-	LVDS data 1st pixel
3	TXACL+	LVDS clock 1st pixel
4	TXACL-	LVDS clock 1st pixel
5	TXA2+	LVDS data 1st pixel
6	TXA2-	LVDS data 1st pixel
7	TXA1+	LVDS data 1st pixel
8	TXA1-	LVDS data 1st pixel
9	TXA0+	LVDS data 1st pixel
10	TXA0-	LVDS data 1st pixel
11	TXB3+	LVDS data 2nd pixel
12	TXB3-	LVDS data 2nd pixel
13	TXBCL+	LVDS clock 2nd pixel
14	TXBCL-	LVDS clock 2nd pixel
15	TXB2+	LVDS data 2nd pixel

Pin	Signal	Description
16	TXB2-	LVDS data 2nd pixel
17	TXB1+	LVDS data 2nd pixel
18	TXB1-	LVDS data 2nd pixel
19	TXVB0+	LVDS data 2nd pixel
20	TXVB0-	LVDS data 2nd pixel
21		
22	SCD_1	Scan Direction
23		
24		
25	GND	Ground
26		
27		
28		
29	SVCC	Switched panel power supply +3,3V/ +5V/ +12V (fused)
30		

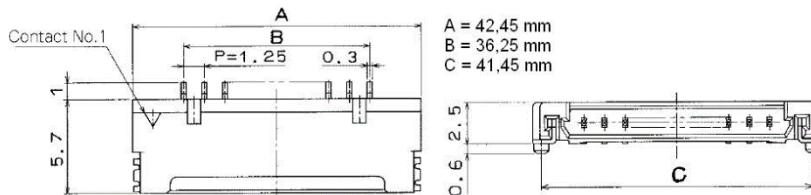

4.3 Backlight

CN8 Backlight Power Supply & Control

Pin	Signal	Description
1	BPS	Backlight power supply
2	BPS	Backlight power supply
3	EBKL	Enabel backlight signal
4	BRCTRL	Brightness Control
5	GND	Ground
6	GND	Ground

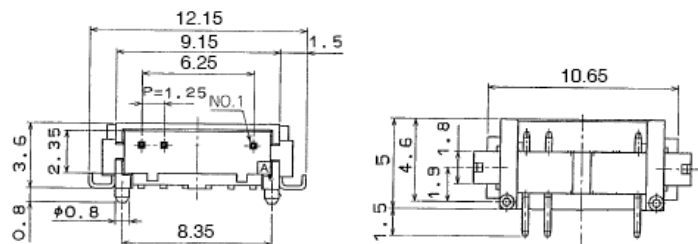

4.4 Board Control

CN5 Keypad Control

Pin	Signal	Description
1	KP_DRV	Reference Voltage for Voltage Divider - ONLY
2	LED_1	Red Status LED
3	LED_2	Green Status LED
4	Key	Voltage Divider Feedback
5	+3.3V	3.3V Low Power Supply
6	GND	Ground

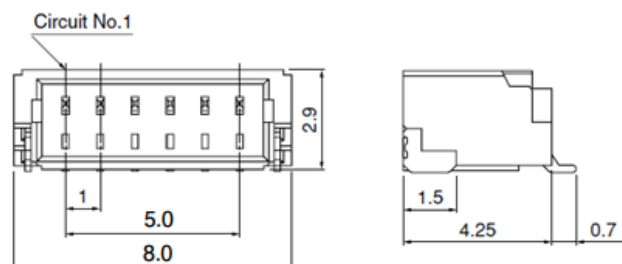

4.5 Peripherals

CN6 I2C-Interface

Pin	Signal	Description
1	+3.3V	3.3V Low power supply
2	Peri_SDA	I ² C data
3	PERI_SCL	I ² C clock
4	I2C_S_INT	Reserved for future use
5	GND	Ground

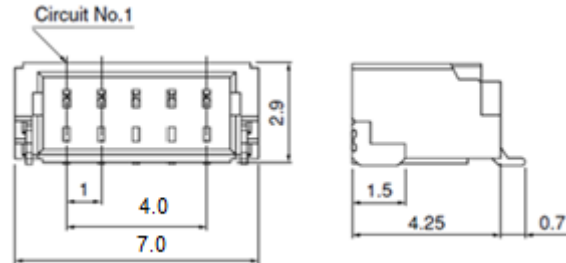

CN10 Audio / Headphone Output

Pin	Signal	Description
1	GND	Ground
2	HOUT_L	Headphone output left
3	HOUT_R	Headphone output right

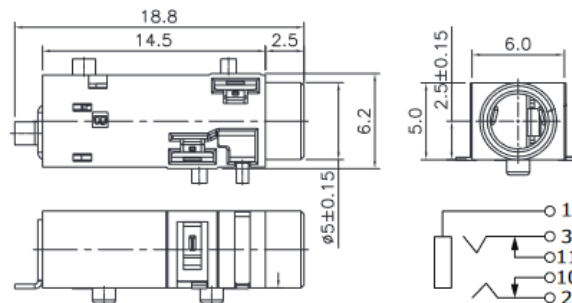
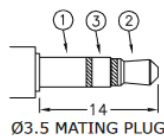

4.6 Firmware Programming

CN1 ISP-Interface

Pin	Signal	Description
1	3.3V_PRG	3.3V programming supply
2	SCLK_PRG	Serial clock
3	MOSI_PRG	Master-out/slave-in data
4	MISO_PRG	Master-in/slave-out data
5	SCE_PRG	Chip-select
6	FLASH_WP	Write protect
7	SPI_SW_RT	Enable programming, active high
8	GND	Ground

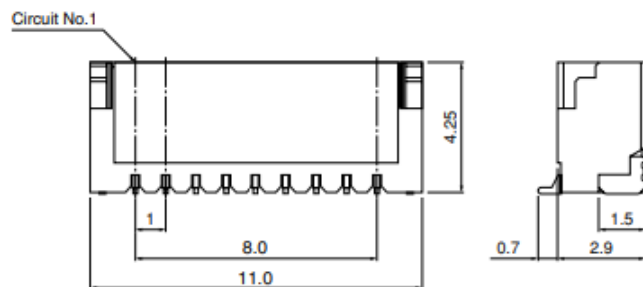

CON_PRG2 ISP-Interface

Pin	Signal	Description
1	3.3V_PRG	3.3V programming supply
2	SCLK_PRG	Serial clock
3	MISO_PRG	Master-in/slave-out data
4	NC	Not conneted
5	SPI_SW_RT	Enable programming, active high
6	SCE_PRG	Chip-select
7	GND	Ground
8	FLASH_WP	Write protect
9	MOSI_PRG	Master-out/slave-in data
10	NC	Not conneted

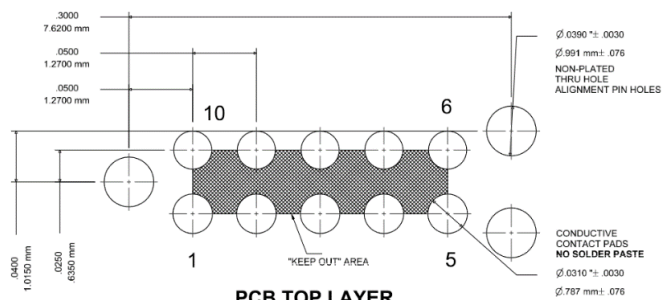

Matching connector/prog-cable:
Tag-connect / TC2050-IDC-NLFP

4.7 Power Supply

CN13 Power Supply Connector (external)

Pin	Signal	Description
Center	+12V/+24V	12V/24V Power supply (max 3A)
Outer Shield	GND	Ground

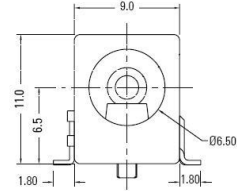

CN12 Power Supply Connector (optional/internal)

Pin	Signal	Description
1	GND	Ground
2	+12V/+24V	12V/24V Power supply

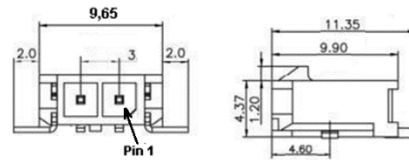

CN12A Power Supply Connector (optional/internal)

Pin	Signal	Description
1	GND	Ground
2	+12V/+24V	12V/24V Power supply

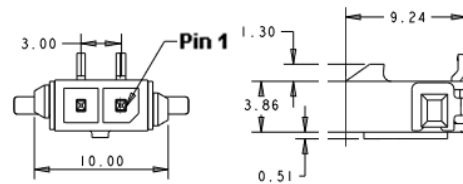

4.8 Connector Overview

CN	Description	Type	Manufacturer
CN1	I2C-Interface	BM10B-SRSS-TB	JST
CN3	HDMI	e.g. 685119134923	Würth
CN4	DP	e.g. DPC-F-S-RA-SMT	Adam-Tech
CN5	Keypad Control	SM06B-SRSS-TB	JST
CN6	I2C-Interface	SM05B-SRSS-TB	JST
CN7	LCD-TFT Interface: LVDS	DF14-30P-1.25	Hirose
CN8	Backlight Supply	53261-0671	Molex
CN10	Headphone Jack	SJ2-3593D-SMT	CUI
CN12	Power Supply	WR-MPC3	Würth
CN12A	Power Supply	2-1445087-2	TE-Connectivity
CN13	Power Supply	2-1445057-2	TE-Connectivity

5 Specifications

5.1 Electrical Characteristics

Operating Values

Item	Condition	MIN.	TYP.	MAX.	Unit	Note
Supply Voltage ¹⁾			12		VDC	*1
Current Input	Stand-by		TBD		mA	
	1920x1200		TBD		mA	Board only
Panel Supply Voltage / Current	+3.3V			2.0	A	Output
	+5V			3.0	A	Output
Supply Voltage ¹⁾		19	24	29	VDC	
Current Input	Stand-by		TBD		mA	
	1920x1200		TBD		mA	Board only
Total 24V to 12V conversion: max 30W						
Panel Supply Voltage / Current	+3.3V			2.0	A	Output
	+5V			3.0	A	Output
Backlight Supply	+12V			TBD	A	Output
Operating Temperature		0	-	70	°C	

*1: Output voltage for display backlight is same as supply voltage

5.2 Temperature & Humidity

Item	MIN.	TYP.	MAX.	Unit	Note
Operating Temperature	0/TBD	-	+70	°C	
Storage Temperature	10/TBD	-	+85	°C	
Humidity	5	-	90	%RHmax	

6 Outline Dimensions

